

Cla-Val

Statement of Qualifications, Capabilities and Commitment to Our Customers

Global Solutions





Table of Contents

Company Overview and Commitments to Our Customers	1
Inventor & Producer of the First Hytrol	2
Onsite Foundries	3
Global Manufacturing Facilities Overview	4
Product Range	5
Training Capabilities and Facilities	6
Online Resources	6
Approvals & Certifications	7
Waterworks Industry Experience and Capabilities	8
Fire Protection Industry Experience and Capabilities	9
Aviation Ground Fueling Industry Experience and Capabilities	10
Marine Industry Experience and Capabilities	11
Quality Control Program	12
Environmental Health & Safety Program	12
Supplemental Product and Company Information	13
Technical, Factory and Sales Contact Information	Back Cover

Cla-Val Statement of Qualifications, Capabilities, and Commitments

Company Overview

Since 1936, Cla-Val has been a leading manufacturer of automatic control valves, serving waterworks, industrial, fire protection, aviation fueling and marine customers throughout the world. Our commitment to excellence and continuous improvement shows in each valve we produce and in the many new products we introduce to the marketplace each year.

Cla-Val is a global company with headquarters and a twenty-acre manufacturing/foundry complex in Newport Beach, California, in addition to production facilities in Canada, Switzerland, France and the United Kingdom.



Cla-Val's long history of manufacturing and industry excellence also enables us to provide the industry's most comprehensive program of hands-on, personalized technical/product training at our in-house training facilities in the US, Canada, Switzerland, the UK and France.

Cla-Val Automatic Control Valves are renowned for their quality and superior performance. The company is also known for consistently excellent customer service as well as innovation, specifically related to products that help to conserve water and energy.

Our company website at www.cla-val.com offers a comprehensive overview of our extensive product line and field service capabilities as well as access to hundreds of technical documents.

Commitments to Our Customers



- Cla-Val is committed to providing the highest quality automatic control valves at fair prices and deliveries in line with our customers' requirements.
- Cla-Val is committed to using ethical business practices with our customers, vendors, employees and other people with whom we come into contact.
- Cla-Val is committed to employing the best possible resources to provide our customers with ongoing improvements, advances and new concepts in our product offering.
- Cla-Val is committed to employing environmentally appropriate technology in all of our business activities.

Cla-Val Statement of Qualifications, Capabilities, and Commitments

Inventor and Producer of the Hytrol Control Valve

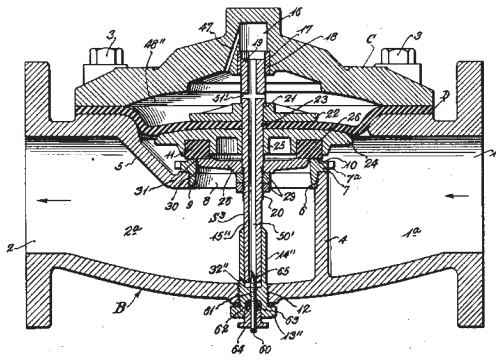

Aug. 31, 1943. D. G. GRISWOLD 2,328,009
Original Filed May 1, 1940

In the Beginning...

In the mid 1930s, the founder of Cla-Val, Donald G. Griswold designed the first hydraulic automatic control valve which was later dubbed the "Hytrol".

The 1940 patent for the Hytrol valve was the first of many new and innovative products Cla-Val would bring to the market-place over the ensuing years.

The tradition of being Inventors, Innovators and Standard Bearers for Excellence lives on at Cla-Val as we near our 75th year in business.

One of the world's first automatic control valve manufacturers

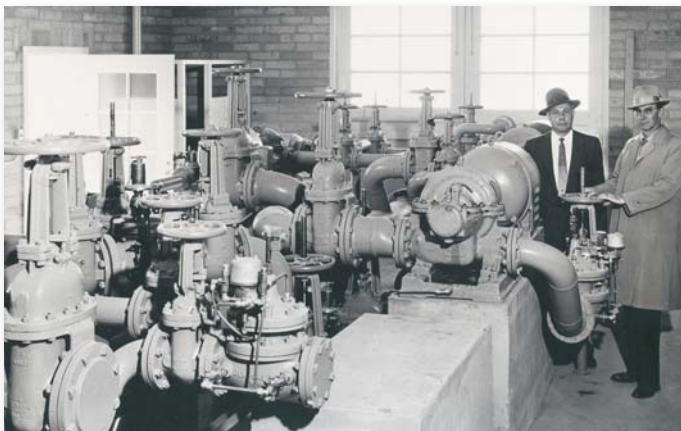

*Innovation
Since 1936...*

Cla-Val Statement of Qualifications, Capabilities, and Commitments

Onsite Foundries

Soundcast Company – Sand casting foundry

Griswold Castings – Investment foundry, lost wax process

By having two on-site foundries, Cla-Val is able to provide castings in over 50 different alloys, making our product offering one of the most extensive in the valve industry. It also allows us to respond more quickly to our customers' unique requirements. A small sample of the many materials our foundries produce include the following alloys:

- Ductile Iron
- Cast Steel
- Stainless Steel
- Monel
- Nickel Aluminum Bronze
- Naval Bronze
- Super Austenitic Stainless Steel
- Super Duplex Stainless Steel
- Titanium



Industrie Service



Soundcast delivers quality.



Cla-Val Statement of Qualifications, Capabilities, and Commitments

Global Manufacturing Facilities Overview

State-of-the art manufacturing equipment:

- Multiple Mazak Multi-Task Milling & Turning; CNC Lathe & Milling machines
- Many more manual machine cells including Vertical Turret Lathes

Large inventory of products on the shelf and ready to ship to meet customers' immediate needs



Computerized Multi-Task Machining



"E-Machine" - The latest in CNC Machining Equipment



Pilot Assembly - Adding the finishing touches



Final Assembly and Inspection



Maintaining a broad range of sizes and configurations to meet our customers' immediate requirements



Committed to keeping an inventory of high demand products for critical applications

Cla-Val Statement of Qualifications, Capabilities, and Commitments

Product Range

Cla-Val offers an extensive range of products from basic hydraulic valves to SCADA compatible electronic control valves to perform the following functions in waterworks, water savings, industrial, fire protection, marine and aviation fueling applications.

Pressure Reducing
Pressure Relief
Pressure Management
Pressure Increasing
Cavitation Prevention
Surge Control
Metering

Pump Control
Rate of Flow/Flow Limiting
Level Control
Tank Filling
Blending
Flushing
Reclaimed Water

Fire Suppression Deluge
Air Release
Vacuum Breaking
Flow Reversal Prevention
Fueling High-Level Shut-Off
Fueling Back Pressure Control
Contamination Monitoring

Size Range

From the smallest: 3/8-inch

To the largest: 48-inches



...and everything in between



Cla-Val Statement of Qualifications, Capabilities, and Commitments

Training Capabilities and Facilities

Cla-Val offers personalized technical assistance, maintenance support, and end-user training programs, including comprehensive engineering, service training and application seminars at the factory and on-site. This, in turn, helps our customers to achieve optimal performance of Cla-Val products during start-up, after installation and through decades of reliable trouble-free service.



Cla-Val USA Training Facility



Cla-Val Canada Training Facility



Cla-Val Europe Training Facility

WWW.CLA-VAL.COM and WWW.CLA-VAL.CH The Definitive Online Resource for Automatic Control Valves

In addition to our experienced staff of Engineers and Product Specialists, Cla-Val's website located at www.cla-val.com (USA) and www.cla-val.ch (Europe) provides round-the-clock technical assistance via access to hundreds of technical documents including:

- Operation, Installation and Maintenance Manuals
- Engineering Data Sheets
- Application Overview Data Sheets
- Parts Lists
- Purchase Specifications
- Surge Prevention Information
- Cavitation Prevention Guidelines
- Pressure Drop Calculator
- Water Savings Calculator
- Downloadable software for Cla-Val Electronic Actuators and other electronic products

Our websites also enable you to locate the Cla-Val product specialist nearest you, register for product training classes or request technical assistance.

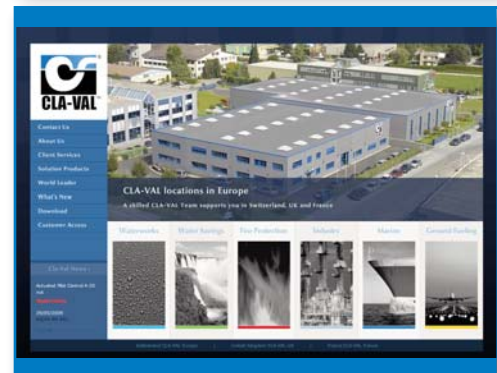

Cla-Val Statement of Qualifications, Capabilities, and Commitments

Approvals and Certifications

Cla-Val's waterworks and fire protection products meet all applicable standards and specifications prescribed by industry organizations such as AWWA, FDA, NSF, UL, and FM International. Along with ISO 9001 certifications for our production facilities in Switzerland and the UK, and ISO 9002 for our manufacturing facility in Canada, Cla-Val also currently holds many other certifications, listings and approvals in North America and around the world.



- National Sanitary Foundation (NSF)
- American Society of Sanitary Engineers (ASSE)
- Canadian Standards Association (CSA)
- Water Regulations Advisory Scheme (WRAS)
- Swiss Gas and Water Industry Association (SVWG)
- Austrian Association for Gas and Water Industries (OVGW)
- International Organization for Standardization (ISO)
- NYC Material and Equipment Acceptance Division (MEA)
- Public Utilities Board Singapore (PUB)
- Technical Standards & Safety Authority (TSSA)
- Underwriter's Laboratory (UL)
- Underwriter's Laboratory Canada (ULC)
- FM Global Technologies (FM)
- Department of the Navy
- Soundcast Foundry: TUV Approval
- American Petroleum Institute
- ATEX



NSF/ANSI STANDARD 61 Drinking Water System Components - Health Effects

Cla-Val Hytrol Valves in sizes from 1-1/4-inches through 36-inches meet the requirements set forth in NSF/ANSI Standard 61.



American Recovery and Reinvestment Act of 2009

Cla-Val Automatic Control Valves meet the "Buy American" Provisions of the ARRA.



Lead Limits for Products used in Waterworks Systems

Cla-Val Automatic Control Valves comply with California Assembly Bill AB 1953 and Vermont S152 that dictates allowable lead levels in products used in water utility distribution piping systems.



Cla-Val Statement of Qualifications, Capabilities, and Commitments

Cla-Val Waterworks Industry Experience and Capabilities



Cla-Val's automatic control valves are specifically designed to meet the requirements of water utility systems, greatly improving supply and distribution system efficiency. Our valves perform with precision and accuracy to provide exact control of pressure, flow, level, surge and pump control. Cla-Val electronic interface control valves combine the efficiency of hydraulic control with advanced technology electronics to provide the optimum SCADA remote control solution.

We also offer products for similar applications in industrial facilities.

Areas of expertise include a wide range of control valve applications for:

- Waterworks Distribution Systems
- SCADA Control
- Water Treatment Plants
- Water Savings
- Reclaimed Water Systems

Visit www.cla-val.com and click on Application Quick Links to see the wide variety of applications for Cla-Val Automatic Control Valves



Pressure Reducing Station in a municipal water distribution system



Water savings with advanced pressure management



Remote SCADA control



Modulating Level Control with Metering



30-Inch Pump Control Valves



Pressure Reducing with Cavitation Protection - Reclaimed Water System

Cla-Val Statement of Qualifications, Capabilities, and Commitments

Cla-Val Fire Protection Industry Experience and Capabilities



From fire suppression systems in high-rise buildings and industrial facilities to the rigorous demands of fire protection systems aboard offshore oil platforms and FPSOs, Cla-Val products provide accurate and reliable performance in the most critical of services. Applications include fire pump pressure relief; pump suction control, deluge, pressure regulation, air release and backflow prevention. Cla-Val Breach Valves protect life and property by preventing fire suppression water supplies from draining in the event of a catastrophic breach in the piping system.

Available in a wide range of special alloys, relevant Cla-Val products are MEA, UL and ULC listed and have Factory Mutual approval.



Commercial High-Rise Fire Protection:
Breach Control, Pressure Reducing,
Pressure Increasing, Fire Pump Control,
Pump Check and Air Release



Commercial High-Rise Fire Protection:
Breach Control, Pressure Reducing,
Pressure Increasing, Fire Pump Control,
Pump Check and Air Release

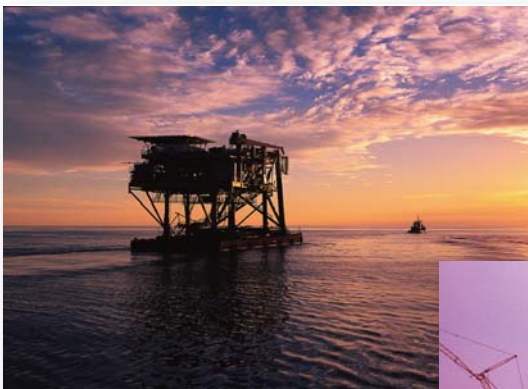

Seawater Service Fire Protection Products for Offshore Platforms and FPSOs :

Deluge, Pressure Reducing,
Pressure Increasing,
Fire Pump Control,
Pump Check and Air Release



Cla-Val Statement of Qualifications, Capabilities, and Commitments

Cla-Val Aviation Ground Fueling Industry Experience & Capabilities



Cla-Val control valves, refueling nozzles, couplers and other ground fueling equipment play a vital role in fuel handling systems for both civilian and military aviation. Our ground fueling products meet or exceed all relevant industry approvals such as API, TÜV, STS-M, MIL-N-5877, MS24484 and all applicable ASTM and ANSI standards. Applications include control of fuel at receiving facilities, storage tanks, fuel/water separation stations, distribution/circulation systems and mobile refuelers and aircraft hot refueling.

From hydrant to aircraft, our proven design and quality workmanship makes Cla-Val one of the most trusted names in the commercial and military aviation industries.



Wide Range Pantograph



Filter and Flow Control



Ground Fueling Cart Conversion



Complete fueling products test facility at factory

Certifications & Approvals

- API Bulletin 1584, Third Edition - hydrant pit valves
- CE# 0036 for automatic control valves
- AF-System Safety Engineering Analysis – pantographs
- NSN – refueling nozzles
- ATEX – fueling nozzles and control valves



Cla-Val Statement of Qualifications, Capabilities, and Commitments

Cla-Val Marine Experience & Capabilities



Cla-Val marine products are designed to meet the exacting requirements of military and commercial shipboard applications. Our automatic control valves are utilized in nearly all of the US Navy's shipboard magazine sprinkler and AFFF fire fighting systems. The military has relied on Cla-Val products for nearly 65 years to protect its personnel in the event of an on-board disaster.

On aircraft carriers, Cla-Val three-way fuel/defuel valves are provided for aircraft fueling and defueling, while other valves control fuel from storage tanks to the flight deck. Additional shipboard applications include cross connection control and lubricating oil pressure control. Specially designed Cla-Val pressure reducing and pressure relief valves are used in seawater systems. Further applications include flow control, solenoid control, and countermeasure wash down, ballasting/de-ballasting and void filling.



**Cla-Val Magazine
Sprinkler Valve**



**Top quality products for Aircraft Carriers,
Frigates, Mine Sweepers, Assault Ships,
Landing Craft, Destroyers, and
Guided Missile Cruisers**

Cla-Val Statement of Qualifications, Capabilities, and Commitments

Cla-Val Quality Control Program

All of Cla-Val's manufacturing processes and practices are verified by the procedures outlined in the Cla-Val Quality Control Manual, which dictates inspection points and controls on product as it moves through the manufacturing steps.

Enforced by the Quality Control Manual, the company provides and maintains an inspection system that will assure that all supplies and services submitted conform to contract requirements whether manufactured by Cla-Val; our foundries; processed by the contractor; or procured from subcontractors or vendors.

We also have in-house state-of-the-art testing facilities and equipment at both our foundry and manufacturing operations to further assure optimum quality in every product we produce



Cla-Val Environmental Health and Safety Program

The Environmental Health and Safety Department is responsible for implementing a program that ensures the health and safety of the company employees and helps minimize environmental impact related to our business operations. The objective the Environmental Health and Safety Program is to prevent personal injury through company-wide adherence to safety procedures and to follow environmental protection measures.

Cla-Val fulfills its mission to create and maintain a safe and environmentally sound workplace by adhering to procedures in the following major areas:

- Hazardous Waste & Materials Management
- Federal, State and Local Regulatory Compliance
- Health & Safety Inspection/Facility Audits
- Accident & Injury Prevention/Investigations
- Education, Training & Protective Equipment
- Safety Standard & Procedures
- Energy Efficient Facility and Systems



Cla-Val Statement of Qualifications, Capabilities, and Commitments

Supplemental Product and Company Information

Cla-Val has an extensive library of technical, marketing and company documentation to assist our customers in understanding the breadth of our product line and to make carefully considered choices when making product selections.

In addition to documents that are available on our website at www.cla-val.com, existing and potential customers may request hard or digital copies of a wide array of technical data sheets, application overview sheets, product animations, product presentations and brochures by contacting their regional sales office, the authorized sales agent for their area or by contacting any of our factories or global locations.



Waterworks Control Solutions

Automatic Control Valves

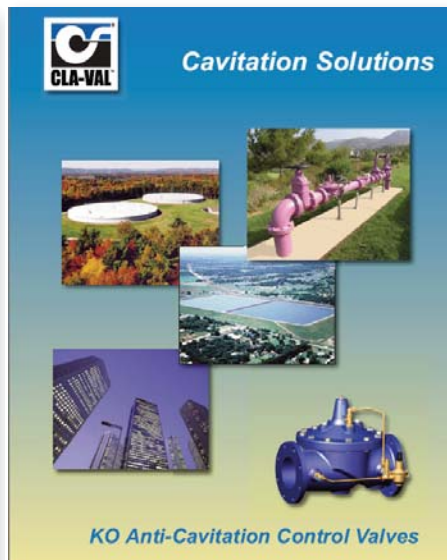

Cavitation Solutions

KO Anti-Cavitation Control Valves

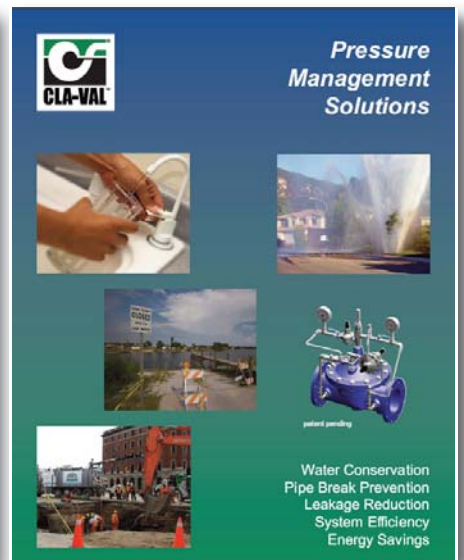

Pressure Management Solutions

Water Conservation
Pipe Break Prevention
Leakage Reduction
System Efficiency
Energy Savings

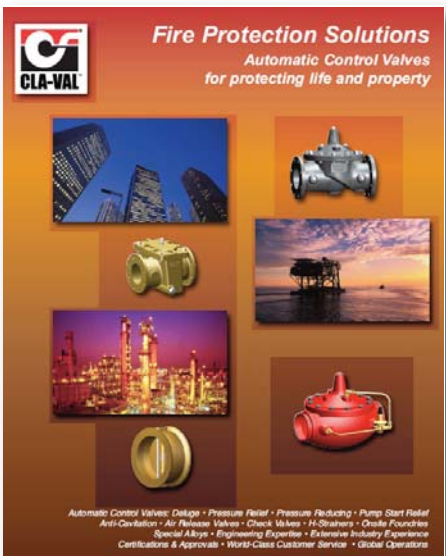

Fire Protection Solutions

Automatic Control Valves for protecting life and property

Automatic Control Valves • Delay • Pressure Relief • Pressure Reducing • Pump Start Relief
Anti-Cavitation • Air Release Valves • Check Valves • H-Strainers • Check Poppets
Special Alloys • Engineering Expertise • Extensive Industry Experience
Certifications & Approvals • World-Class Customer Service • Global Operations

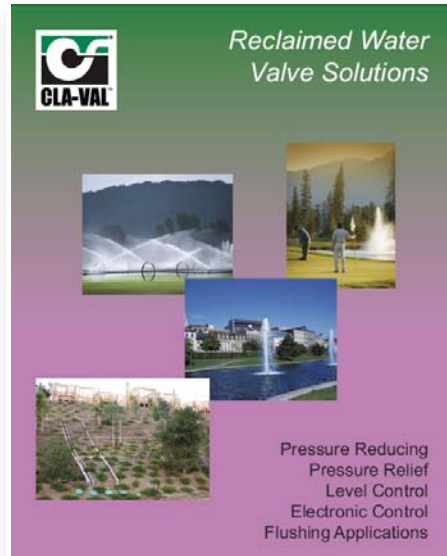

Reclaimed Water Valve Solutions

Pressure Reducing
Pressure Relief
Level Control
Electronic Control
Flushing Applications

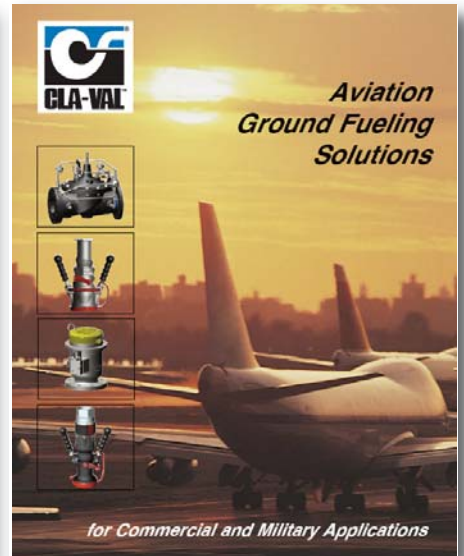

Aviation Ground Fueling Solutions

for Commercial and Military Applications

GLOBAL HEADQUARTERS

P.O. Box 1325
Newport Beach, CA 92659-0325
Phone: (949) 722-4800
800-942-6326
Fax: (949) 548-5441
www.cla-val.com
E-mail: claval@cla-val.com



US WESTERN REGION

11626 Sterling Avenue, Suite F
Riverside, CA 92503
Phone: (951) 687-9145
800-247-9090
Fax: (951) 687-9954
E-mail: lvanderk@cla-val.com

CLA-VAL EUROPE

Chemin des Mesanges 1
CH-1032 Romanel/Lausanne Switzerland
Phone: 41-21-643-15-55 • Fax: 41-21-643-15-50
E-mail: cla-val@cla-val.ch

US SOUTHERN REGION

11500 NW Freeway, Suite #200Q
Houston, TX 77092
Phone: (713) 681-9559
800-533-8181
Fax: (713) 681-9779
E-mail: blindsey@cla-val.com

CLA-VAL UK

Dainton House, Goods Station Road
GB - Tunbridge Wells
Kent TN1 2 DH England
Phone: 44-1892-514-400 • Fax: 44-1892-543-423
E-mail: info@cla-val.co.uk

CLA-VAL FRANCE

Porte du Grand Lyon 1
ZAC du Champ du Périer
France - 01700 Neyron
Phone: 33-4-72-25-92-93 • Fax: 33-4-72-25-04-17
E-mail: cla-val@cla-val.fr

US NORTHERN REGION

P.O. Box 863
Elgin, IL 60121
280 Willard Avenue
Elgin, IL 60120
Phone: (847) 697-1413
800-238-7070
Fax: (847) 697-5549
E-mail: djurs@cla-val.com

CLA-VAL CANADA

4687 Christie Drive
Beamsville, Ontario
Canada L0R 1B4
Phone: (905) 563-4963 • Fax: (905) 563-4040
E-mail: sales@cla-val.ca

US EASTERN REGION

6911 Richmond Highway, Suite 444
Alexandria, VA 22306
Phone: (703) 721-1923
800-451-3030
Fax: (703) 721-1927
E-mail: bmoore@cla-val.com

CLA-VAL PACIFIC

308 Port Hills Road
Christchurch New Zealand
Phone: 64-39644860
Fax: 64-39644876
Email: gnuthall@cla-val.com

800.942.6236
www.cla-val.com